



Standard Test Method for Determination of Modulus of Elasticity for Rigid and Semi- Rigid Plastic Specimens by Controlled Rate of Loading Using Three-Point Bending¹

This standard is issued under the fixed designation D 5934; the number immediately following the designation indicates the year of original adoption or, in the case of revision, the year of last revision. A number in parentheses indicates the year of last approval. A superscript epsilon (ϵ) indicates an editorial change since the last revision or reapproval.

1. Scope

1.1 This test method covers the use of controlled rate of loading mechanical instrumentation for gathering and reporting the modulus of elasticity of thermoplastic and thermosetting resins and composite systems in the form of rectangular bars molded directly or cut from sheets, plates, or molded shapes. The data generated, using three-point bending techniques, may be used to identify the thermomechanical properties of a plastics material or composition using a controlled rate of loading mechanical instrument.² Results obtained from this test method may or may not be comparable to results obtained using D 790.

1.2 This test method is intended to provide a means for determining the modulus of elasticity within the linear region of the stress-strain curve (see Fig. 1). This test is conducted at standard temperature and pressure.

1.3 Apparent discrepancies may arise in results obtained under differing experimental conditions. These apparent differences from results observed in another study can usually be reconciled, without changing the observed data, by reporting in full (as described in this test method) the conditions under which the data were obtained.

1.4 The values stated in SI units are to be regarded as the standard. The values stated in parentheses are for information only.

1.5 *This standard does not purport to address all of the safety concerns, if any, associated with its use. It is the responsibility of the user of this standard to establish appropriate safety and health practices and determine the applicability of regulatory limitations prior to use.*

NOTE 1—There is no similar or equivalent ISO standard.

¹ This test method is under the jurisdiction of ASTM Committee D20 on Plastics and is the direct responsibility of Subcommittee D20.10 on Mechanical Properties.

Current edition approved April 10, 2002. Published June 2002. Originally published as D 5934 – 96. Last previous edition D 5934 – 96.

² This apparatus is available from the Perkin-Elmer Corporation, 761 Main Avenue, Norwalk, CT 06859-0256.

2. Referenced Documents

2.1 *ASTM Standards:*

D 618 Practice for Conditioning Plastics for Testing³

D 638 Test Method for Tensile Properties of Plastics³

D 883 Terminology Relating to Plastics³

D 1999 Guide for the Selection of Specimens and Test Parameters from ISO/IEC Standards⁴

D 4092 Terminology for Plastics: Dynamic Mechanical Properties⁵

E 177 Practice for the Use of the Terms Precision and Bias in ASTM Test Methods⁶

3. Terminology

3.1 *Definitions:* Definitions of terms applying to these test methods appear in Terminologies D 883 and D 4092, and Annex A1 and Annex A2 of Test Method D 638.

4. Summary of Test Method

4.1 A specimen of rectangular cross section is tested in flexure as a beam. The bar rests on two supports and is loaded by means of a loading nose midway between the supports. The test specimen of known geometry is placed under mechanical linear displacement at isothermal conditions by using a controlled rate of loading. The modulus of elasticity is measured using three-point bending.

5. Significance and Use

5.1 This test method provides a simple means of characterizing the mechanical behavior of plastics materials using very small amounts of material. The data obtained may be used for quality control, research and development, and establishment of optimum processing conditions.

5.2 Mechanical testing provides a sensitive test method for determining mechanical characteristics by measuring the modulus of elasticity.

³ *Annual Book of ASTM Standards*, Vol 08.01.

⁴ Discontinued; see *1999 Annual Book of ASTM Standards*, Vol 08.01.

⁵ *Annual Book of ASTM Standards*, Vol 08.02.

⁶ *Annual Book of ASTM Standards*, Vol 14.02.

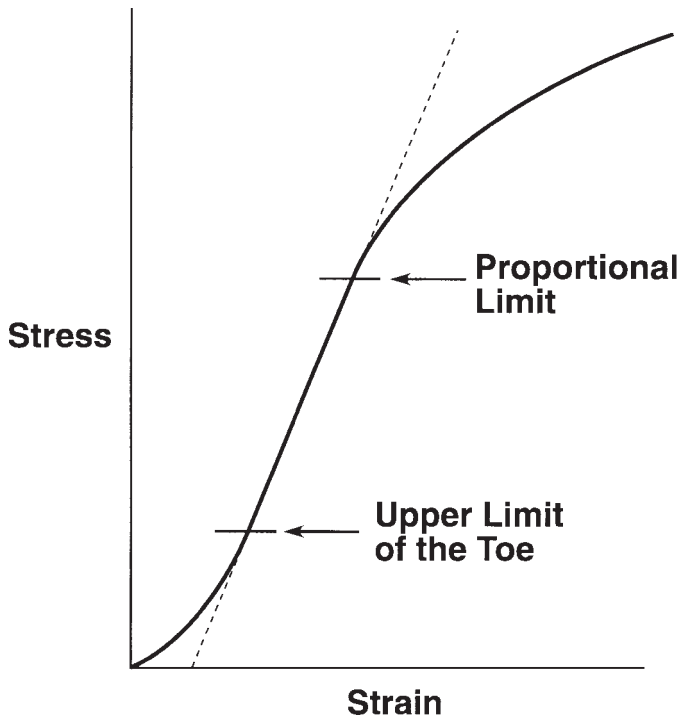

FIG. 1 Stress-Strain Curve (Linear Region)

NOTE 2—Materials that are suspected to be too anisotropic may not be suitable for this test method.

5.3 This test method can be used to assess:

5.3.1 The effects of processing treatment,

5.3.2 Relative resin behavioral properties, including cure,

5.3.3 The effects of substrate types and orientation (fabrication) on modulus, and

5.3.4 The effects of formulation additives that might affect processability or performance.

6. Interferences

6.1 Since small test specimen geometries are used, it is essential that the specimens be representative of the polymeric material being tested.

7. Apparatus

7.1 The function of the apparatus is to hold a rectangular test specimen of a polymeric material system so that the material acts as the elastic and dissipative element in a mechanically driven linear displacement system. Displacements (deflections) are generated using a controlled loading rate applied to a specimen in three-point bending configuration.

7.2 The apparatus shall consist of the following:

7.2.1 *Loading Nose and Supports*—The loading nose and supports shall have cylindrical surfaces having a sufficient radius to avoid excessive indentation or failure due to stress concentration directly under the loading nose (see Fig. 2).

7.2.2 *Detectors*—A device or devices for determining dependent and independent experimental parameters, such as force (stress) or deflection (strain), and temperature. Temperature should be measurable with a precision of $\pm 1^\circ\text{C}$, deflection to $\pm 1\%$ full scale, and force to $\pm 1\%$ full scale.

7.3 *Optional Accessories:*

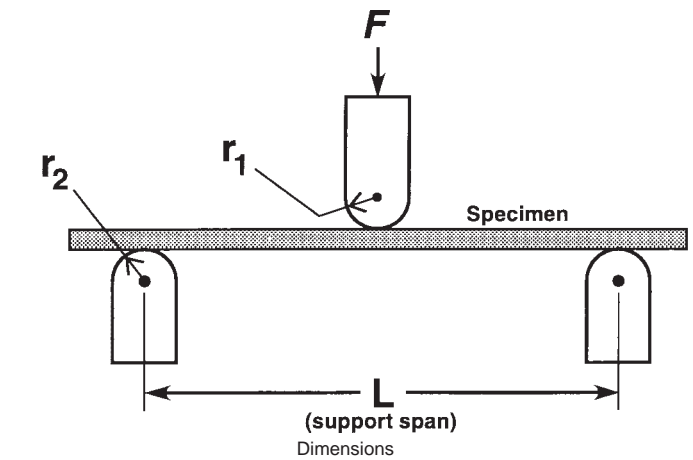

Description	Symbol	Dimension, mm	Tolerance, \pm mm
Support span	L	20.0	0.1
Loading nose radius	r^1	3.0	0.5
Support radius	r^2	1.0	0.1

FIG. 2 Loading Members

7.3.1 *Temperature Controller and Oven*—A device for controlling the temperature, either by heating (in steps or ramps), cooling (in steps or ramps), maintaining a constant specimen environment or a combination of both. A temperature controller should be sufficiently stable to permit measurement of environmental-chamber temperature to within 1°C .

7.3.2 *Nitrogen*—Or other inert gas supply, for purging purposes.

8. Test Specimens

8.1 The specimens may be cut from sheets, plates, or molded shapes, or may be molded to the desired finished dimensions. Specimens shall be long enough to allow overhanging on each end of at least 10% of the support span. Overhang shall be sufficient to prevent the specimen from slipping through the supports. A typical rectangular test beam is tested flatwise on a support span (see Fig. 3 and Fig. 4).

8.2 At least five specimens shall be tested for each sample.

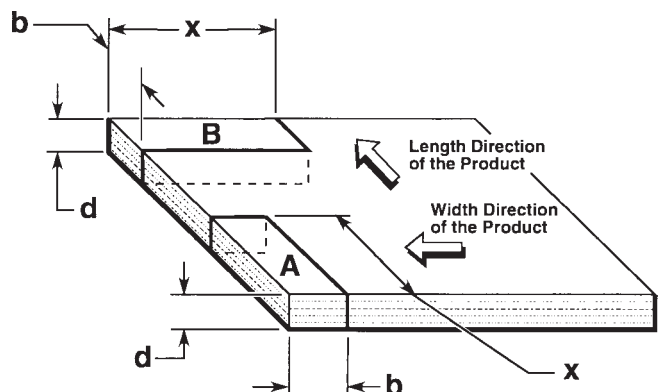

FIG. 3 Specimen Dimensions (Test Specimen Taken from a Sheet)